



## 1. Product Name

Clip-on Prism

## 2. Product Code

13383 – 3-facet prism

19934 – 4-facet prism

## 3. Colour

Black

## 4. Brief Description

Reproduces the original effect three times with the 3-facet prism and four times with the 4-facet prism and gives the illusion of movement.

## 5. Contents

- 1 x prism

## 6. Snoezelen® Stimulations

- Sight

## 7. Best Use

Use with a ROMPA® Projector in a darkened environment. Project onto a clear, white or pale-coloured wall.

## 8. Compatible ROMPA® Products

18530-1 – Super Solar 100C Projector

20997 – LED Projector

ROMPA® offers an extensive range of effect wheels and Projector accessories. Visit [www.rompa.com](http://www.rompa.com) for more information. The following wheels are especially effective with the Prisms:

19930 – Spring

19931 – Summer

19932 – Autumn

19933 – Winter

## 9. Starting Up

- Switch the projector OFF.
- Release the screws on the rim of the Clip on Prism.
- Slot the Prism over the Projector lens and tighten the screws.
- Switch the projector ON.

## 10. Detailed Description

Reproduces the original effect three times with the 3-facet prism and four times with the 4-facet prism and gives the illusion of movement. The Spring, Summer, Autumn and Winter Effect Wheels are especially effective when used with the 4-facet prism.

3 Facet



4 Facet  
FG6230

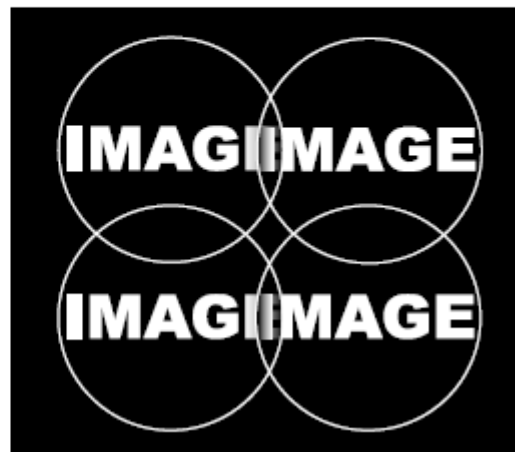
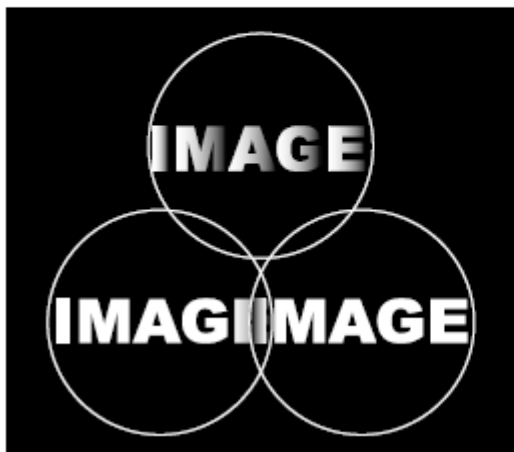

## 11. Safety

- Supervise the use of this product. Please refer to the separate instructions for the Projector.

## 12. Technical Specification

*Not applicable*

## 13. Installation

1. Switch the projector OFF.
2. Release the three screws on the rim of the Clip on Prism.
3. Slot the Prism over the Projector lens and tighten the screws.
4. Switch the projector ON.

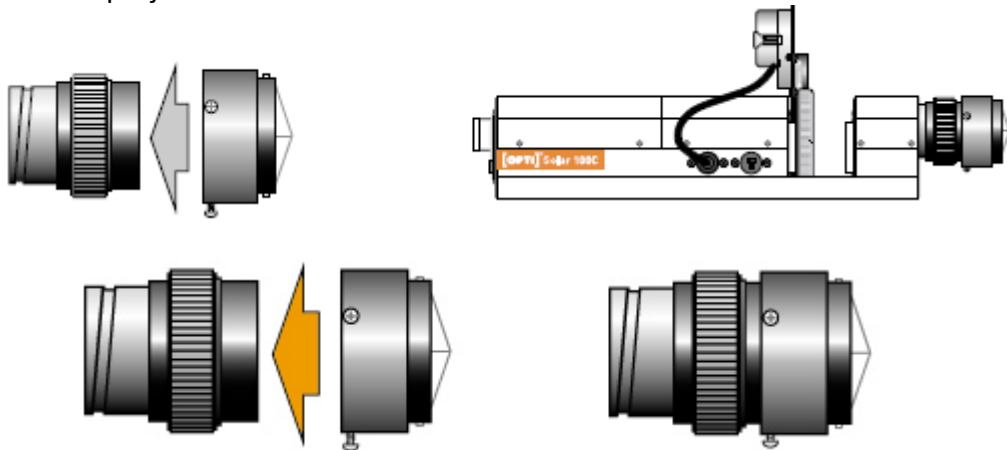

## 14. Care and Maintenance

- When removing the Clip-On Prism, take care not to remove the 'click-clack' (the protruding part from the front) of the projector.
- Clean the Prism with a soft cloth.

## 15. Troubleshooting

*Not applicable*

Further copies of these instructions can be downloaded at [www.rompa.com](http://www.rompa.com)

We hope you find our instructions invaluable. If you have any suggestions for improving them further your comments will be greatly received – please contact us at [producthelp@rompa.com](mailto:producthelp@rompa.com)