

Hip Hop Activity Box™

Instruction Manual

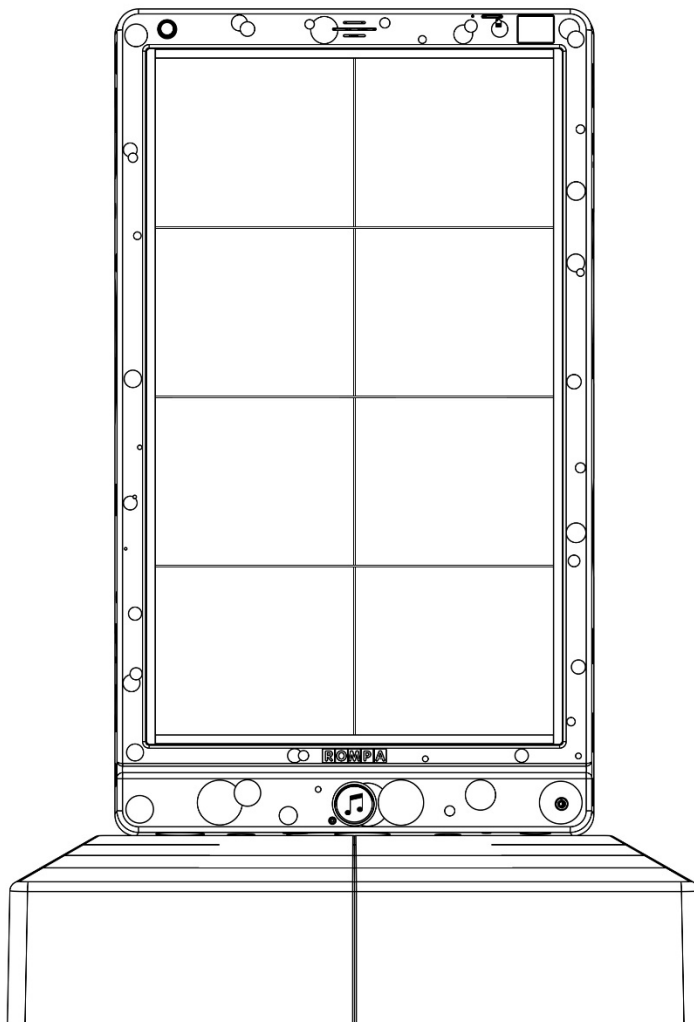

Contents

3	Panel Overview
5	Colour
5	Description
5	Technical Specification
6	Dimensions
7	Contents
8	Compatible Rompa® Products
9	Operation
9	Modes
12	Touch Screen
16	Illuminated Push Buttons
16	External Switches
17	Microphone Input
17	Themes
18	Rompa® Wireless Operation
20	Installation
26	Safety
27	Care and Maintenance
28	Troubleshooting

Panel Overview (Front)

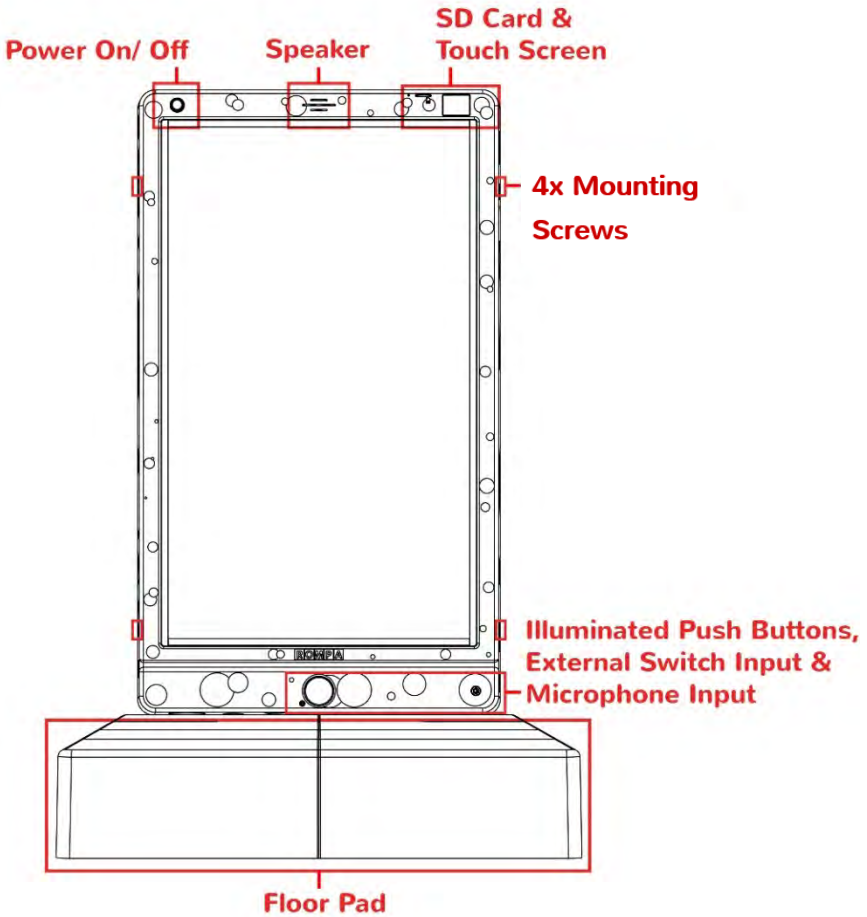

Panel Overview (Back)

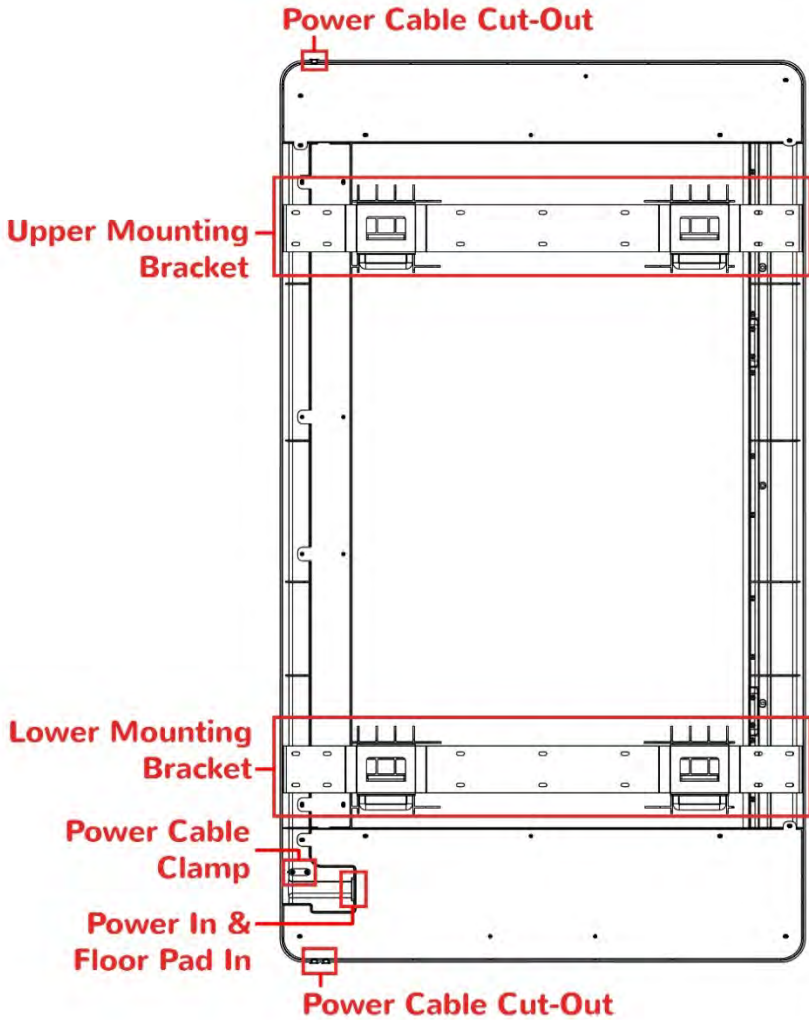

Colour

The Panel is available in 7 colours:
Black, White, Blue, Red, Green, Lilac, & Ice Blue.

Description

Play games, create music and trigger shows of light and colour all using the soft play floor pad. The panel is packed with games, music and sound effects for endless hours of fun and learning. Encourage movement, creativity and composition, listening skills, meaningful activity and an understanding of cause and effect.

Technical Specification

Weight:	12kg
Input:	100-240V 50/60Hz
Output:	5V DC 10A
Material:	ABS (Phthalate-Free)

Dimensions

(All dimensions in mm)

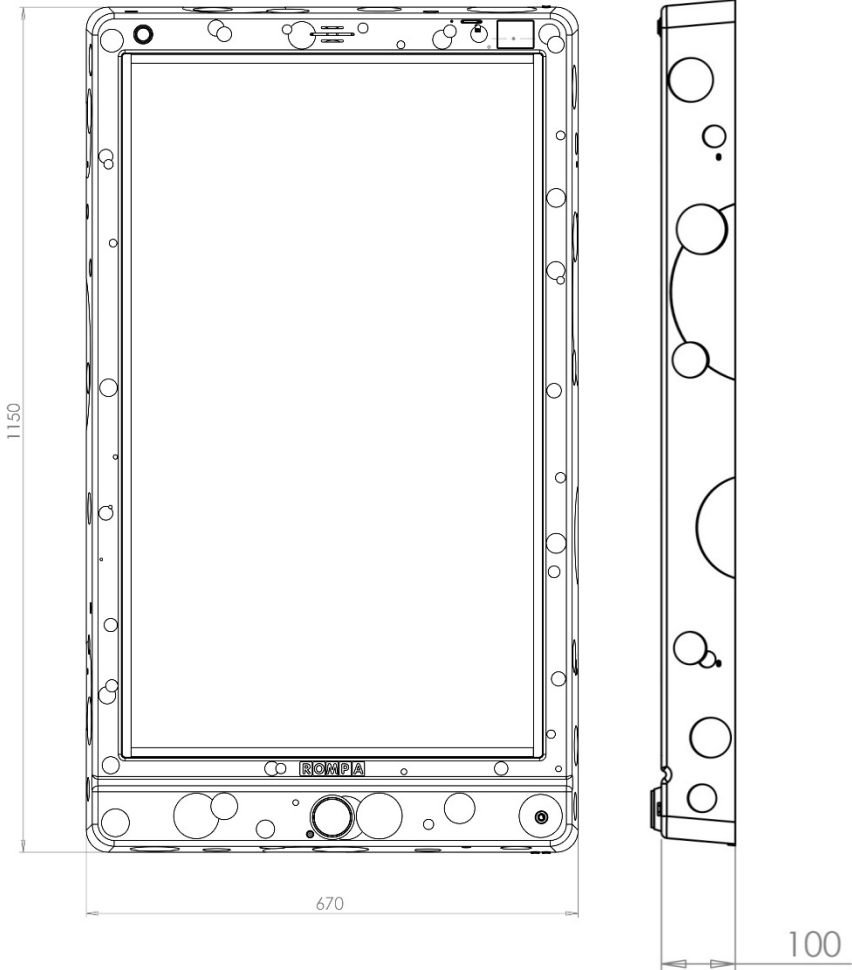

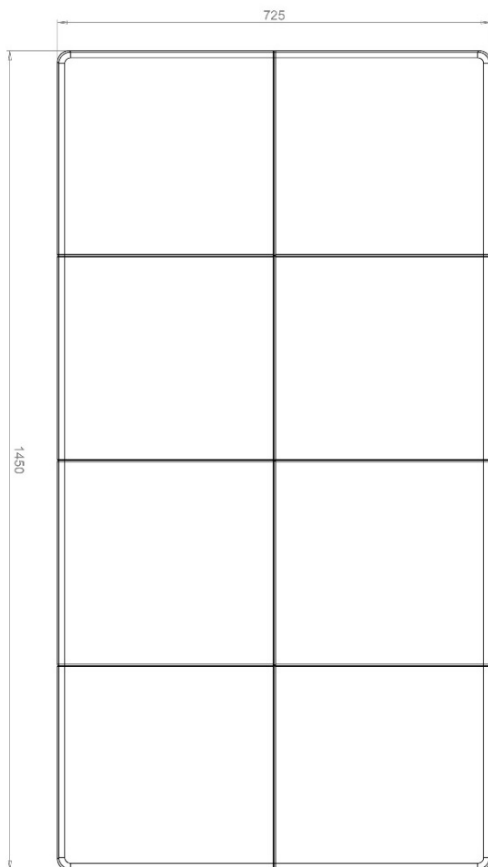

Contents

- 1x Hip Hop Activity Box™ Wall Panel
- 1x Hip Hop Activity Box™ Floor Pad
- 2x Wall Mounting Bracket
- 4x M4 Screws
- 1x UK Mains Lead
- 1x US Mains Lead
- 1x EU Mains Lead

Compatible Rompa® Products

20848 Sensory Magic®

21098 Sensory Magic Portable®

19847 Deluxe 8 Colour Wirefree Controller

21006 8 Colour Wirefree Switch

19939 WiFi Interactive Carpet Switch Set

18870 Talking Cube

20402 Mini Talking Cube

21917 WiFi Microphone

24515 Colour Command Centre™

21918 WiFi Override Transmitter

21728 WiFi App Control Box

22867 Wireless Colour Controller Cushion Wall Mat

Operation

Modes

The mode dictates how the panel behaves. The Hip Hop Activity Box™ has 6 modes which can be selected via the touch screen and an additional mode when a microphone is plugged into the ¼"/6.35mm microphone input:

Mode 1: One Light/ One Note

When a colour on the floor pad is selected the entire panel screen will light up the same colour and play an associated sound effect. The sound effect played is determined by the theme selected via the illuminated push button and colour on the floor pad.

The user must wait until the sound effect finishes before they can trigger a new colour/ sound effect. To trigger the same colour and sound effect twice in a row the user must step off and back onto the floor pad.

Mode 2: Multiple Lights/ Multiple Notes

When a colour on the floor pad is selected the corresponding square on the panel screen will light up the same colour and play an associated sound effect. The sound effect played is determined by the theme selected via the illuminated push button and colour on the floor pad.

The user does not have to wait until the sound effect finishes before they can trigger a new colour/ sound effect. To trigger the same colour and sound effect twice in a row the user must step off and back onto the floor pad.

Mode 3: Lights Out

A game is started by pressing any button on the floor pad which will trigger a 3 second auditory countdown. The panel will illuminate a random number of squares (dependant on difficulty selected) and the user has to press the corresponding colours on the floor pad to extinguish the lights and score points. The user must score as many points as possible before the time runs out. An auditory and visual reward is played when the game ends and the score is displayed via the touch screen.

To trigger the same colour twice in a row the user must step off and back onto the floor pad.

Mode 4: Colour Memory

A game is started by pressing any button on the floor pad which will trigger a 3 second auditory countdown. The panel will illuminate a random square which will then extinguish. The user has to press the corresponding colours on the floor pad to score a point. The panel will then display the same colour again but add a second colour to the sequence. This will continue until user incorrectly repeats the sequence of lights shown by the panel. An auditory and visual reward is played when the game ends and the score is displayed via the touch screen.

To trigger the same colour twice in a row the user must step off and back onto the floor pad.

Mode 5: Song and Lights

A song and light pattern is linked to each colour of the floor pad. Selecting a colour on the floor pad will trigger the pattern and song to start playing. At any time the user can select a different song and pattern by stepping on another colour.

To trigger the same colour twice in a row and start the song from the beginning the user must step off and back onto the floor pad.

The 'Theme' illuminated push button is inactive in this mode.

Mode 6: Create a Song

The user must first select a song by stepping on a colour of the floor pad (a different song is associated with each colour). This will trigger a 3 second auditory countdown. The panel will then illuminate a random number of squares. The user must select the corresponding colour on the floor pad to extinguish the light and play the first note or segment of the song (depending on difficulty will determine the number of steps required to finish the song). The user must continue to extinguish the lights to finish the song. An auditory and visual reward is played when the song is complete.

To trigger the same colour twice in a row and start the song from the beginning the user must step off and back onto the floor pad.

The 'Theme' illuminated push button is inactive in this mode.

Microphone Mode

This mode cannot be accessed via the touch screen. To access this mode plug a microphone into the ¼"/6.35mm microphone input. The panel will automatically change to microphone mode once a microphone has been detected. The mode and brightness of the panel cannot be adjusted via the touchscreen whilst a microphone is plugged in.

Use the floor pad to change the colour of the panel. The brightness of the panel is then controlled by the volume of sounds made. The louder the sound the brighter the panel will go.

All Modes: Passive Colour

When the panel has been inactive for more than 5 minutes the panel will fade through colours creating a relaxing passive effect.

Touch Screen

The touch screen is intended for the supervisor of the session not the primary user of the panel. The touch screen allows you to control in detail how the panel behaves as well as view statistics of panel usage.

Upon booting the panel up it will revert to its default settings:

Mode 1: Interactive

Volume: 2

Touch Screen Brightness: 100%

Panel Brightness: 100%

Sound Effects: On

WiFi: On

Lock: Off

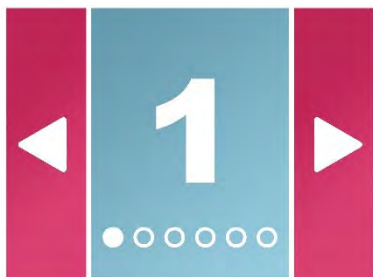

Mode

Press the light blue mode button to cycle through the modes of the panel.

Press the red forward or back buttons to cycle through the other menu options.

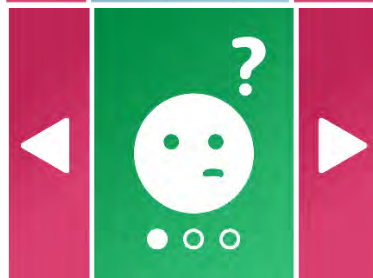

Difficulty

Pressing at the face will give you different levels of difficulty in that mode. The level of difficulties are:

- Green = Easy
- Orange = Intermediate
- Red = Advanced

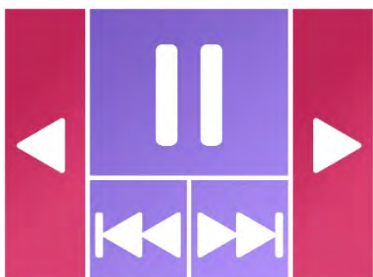

Media*

Pressing the 'play/ pause' button to play or pause music. Press the 'skip forward' to play the next track or 'skip back' to play the previous.

Press the red forward or back buttons to cycle through the other menu options.

*An SD Card with compatible mp3 files must be inserted to use the media functionality.

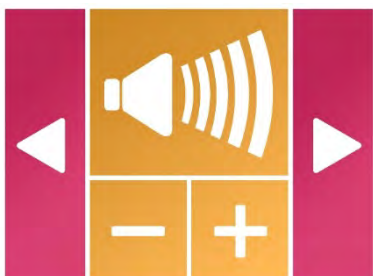

Volume

Pressing the '+' will increase the volume and pressing '-' will reduce the volume.

Press the red forward or back buttons to cycle through the other menu options.

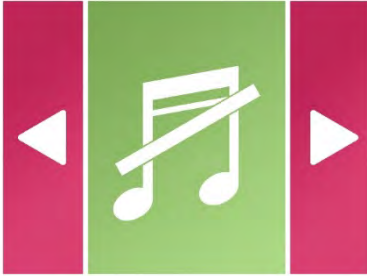

Sound Effects

Pressing the light green sound effect button will cycle the sound effects on or off. Sound effect refers to the sounds made when the user activates the illuminated push buttons.

Press the red forward or back buttons to cycle through the other menu options.

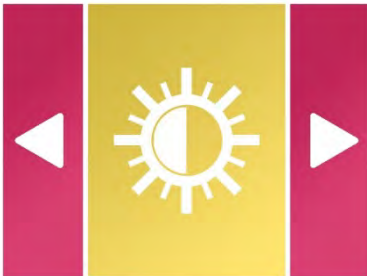

Touch Screen Brightness

Pressing the yellow touch screen brightness button will cycle the touch screen through 6 levels of brightness.

Press the red forward or back buttons to cycle through the other menu options.

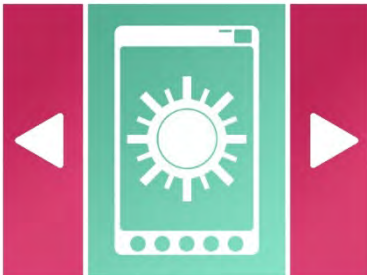

Panel Brightness

Pressing the light Turquoise screen brightness button will cycle the panel through 3 levels of brightness.

Press the red forward or back buttons to cycle through the other menu options.

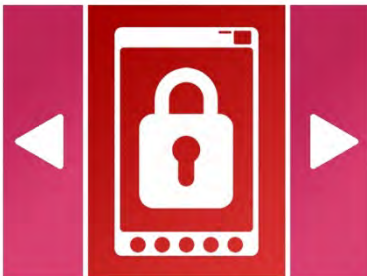

Lock

Pressing the red lock button will lock and unlock the illuminated push buttons. When locked the push buttons will dim and be unresponsive.

Press the red forward or back buttons to cycle through the other menu options.

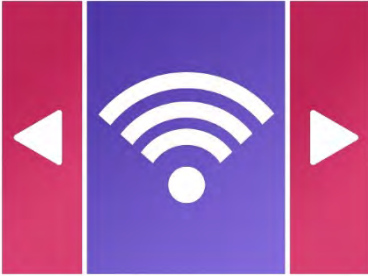

Wireless

Pressing the purple wireless button will cycle the panel Wireless on or off. With wireless turned on the panel will respond to other Rompa® compatible wireless products. With wireless turned off it will ignore Rompa® compatible wireless products. (see page 6)

Press the red forward or back buttons to cycle through the other menu options.



Stats

Pressing the blue stats will open the stats screen.

From the stats screen you can see real time the amount of button presses have been made on the panel and the duration the panel has been used for.

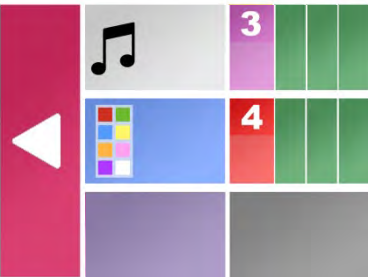

To return to the main menu press the red backward button

Press the red forward or back buttons to cycle through the other menu options.

Illuminated Push Buttons

The Hip Hop Activity Box™ has 1 illuminated push button so the user can control select the theme of sound effects associated with the panel. When pressed the button will flash and a unique sound effect will be triggered. Sound effects can be

turned off via the touch screen. Illuminated buttons can also be locked via the touch screen if required. The brightness of the illuminated buttons is reduced and the buttons are unresponsive when locked.



Theme

The panel has 7 themes which can be selected via the 'Theme' illuminated push button or an external switch plugged into the 'Theme' ¼"/6.35mm input jack.

Theme dictates the sound effects which are triggered when interacting with the floor pad.

External Switches

The panel has 1 external switch input each located underneath their associated illuminated push button. To connect the external switch simply plug into the ¼"/6.35mm jack and remove when finished (external switches without a ¼"/6.35mm jack may need an adapter fitting).

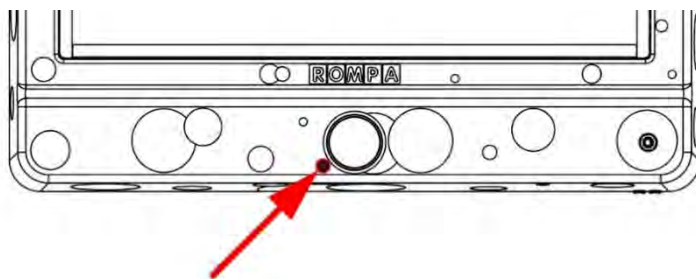

Microphone Input

The panel has 1 microphone input. To use a microphone with the panel simply plug a microphone into the ¼"/6.35mm jack located in the bottom right of the

panel. When the microphone is inserted the panel will automatically detect its presence and turn to 'Microphone Mode'. The panel also acts as a karaoke and sounds spoken through the microphone can be heard through the integrated speaker. Simply remove the microphone from the panel when finished and the panel will automatically revert back to its previous mode.

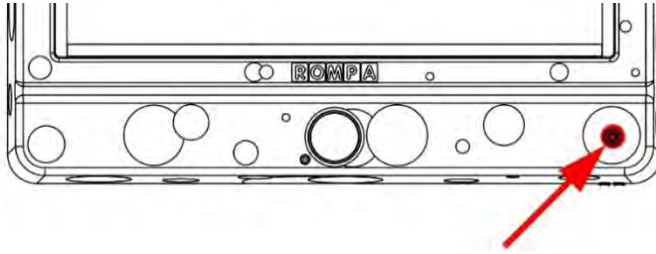

Themes

The panel has 7 themes which can be selected via the 'Theme' illuminated push button or an external switch plugged into the 'Theme' input jack:

- 1 Piano
- 2 Various Instruments
- 3 Space
- 4 Carnival
- 5 Animals
- 6 Music
- 7 Guitar

Rompa® Wireless Operation

The Hip Hop Activity Box™ is compatible with a range of Rompa® wireless products (see Compatible Rompa® Products).

The panel has two unique modes of operation with wireless products which are Colour Mode and Game Mode. The panel will always start in Colour Mode and Game Mode can only be selected using either an 8 Colour Wireless Controller Simple (21006) or Deluxe (19847) by selecting the central 'Function Button':

Colour Mode

8 Colour Wirefree Controller: Simple and Deluxe

Pressing the colour buttons turns the all the panel the corresponding colour selected. The panel will remain this colour unless a new colour is selected via the panel or a Rompa® wireless controller or the panel will return to its normal operation by using the floor pad or timing out after 60 seconds.

Pressing the central 'function button' will switch the panel to the Game Mode.

Other Wireless Products

Selecting a colour turns the panel the corresponding colour selected. The panel will remain this colour unless a new colour is selected via the panel or a Rompa® wireless controller or the panel will return to its normal operation by using the floor pad or timing out after 60 seconds.

Game Mode

It is recommended that only an 8 colour controller is used with game mode as the 8 colours on the controller match the 8 colours on the floor pad.

8 Colour Wirefree Controller: Simple and Deluxe

Pressing the colour buttons acts as pressing the corresponding colour on the floor pad. This means games and songs can be played via the wireless controller instead of the floor pad. The panel works as normal in this mode.

Pressing the central 'function button' acts will switch the panel back to Colour Mode.

Other Wireless Products

Selecting a colour acts as pressing the corresponding colour on the floor pad. This means games and songs can be played via the wireless controller instead of the floor pad. The panel works as normal in this mode.

The panel will ignore any colour which is not present on the floor pad e.g. shades of green which are not same as the green on the floor pad or 8 colour controllers will be ignored.

Some games require the user to be able to select all 8 colours of the floor pad or 8 colour controller. This means some wireless controllers will be poorly suited to Game Mode e.g. Talking Cube (18870) you can only select 6 colours.

Installation

Installing Wall Mount Brackets & Panel

Ensure that, after installation, the mains plug and/or power switch for the Panel is easily accessible to facilitate removal of power.

Due to the size of the product it is recommended that two people are required to install the product.

Recommended Tools

- Drill
- Spirit Level
- Pencil
- Tape Measure
- Appropriate Fixings e.g. Wall Plugs

(All dimensions in mm)

MAX screws in total per bracket: 14

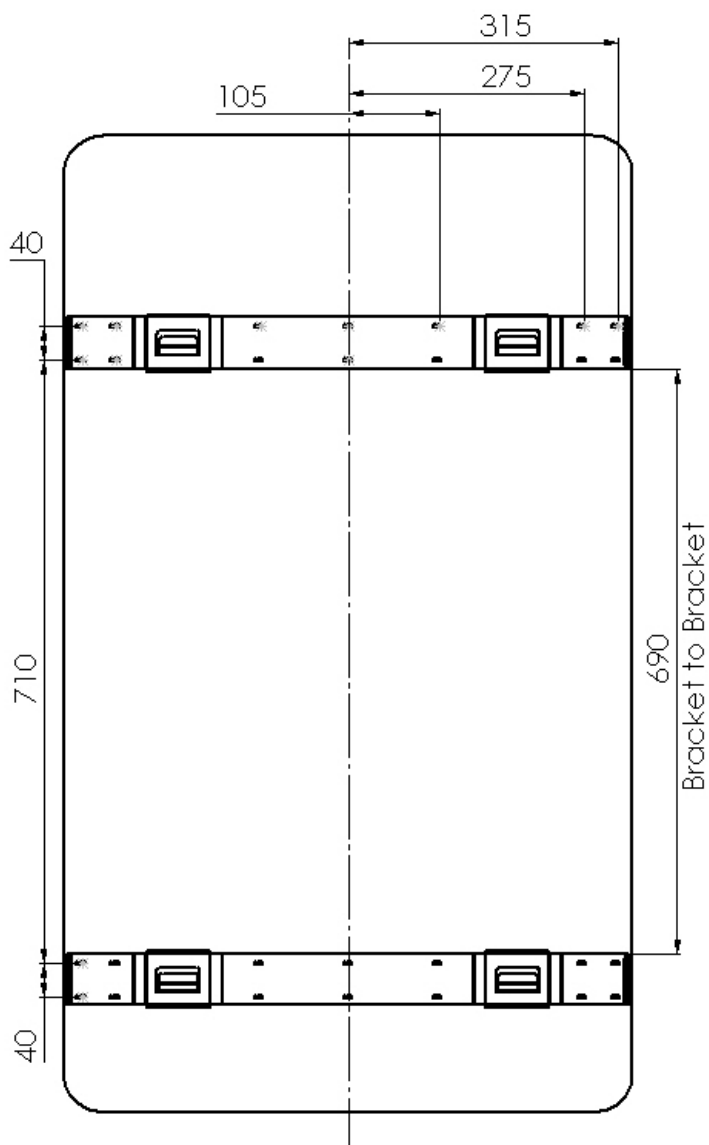

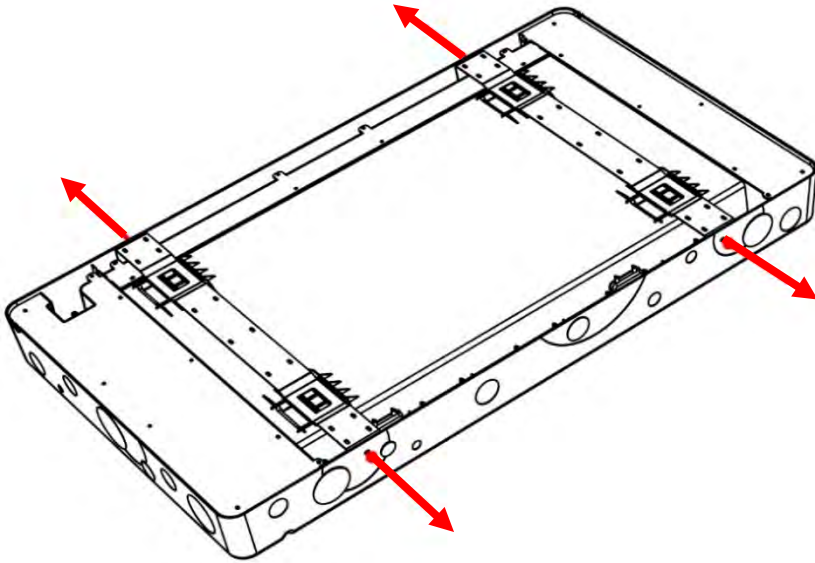

1. Unscrew the 4x M4 screws which secure the 2x brackets to the panels. The brackets are secured to avoid any damage during transit.

Be sure to place the 4x M4 screws in a safe place as they will be required later.

2. Remove the brackets from the panel by sliding the bracket down and then lift them out of panel.

Place the brackets safely to one side as they will be required later.

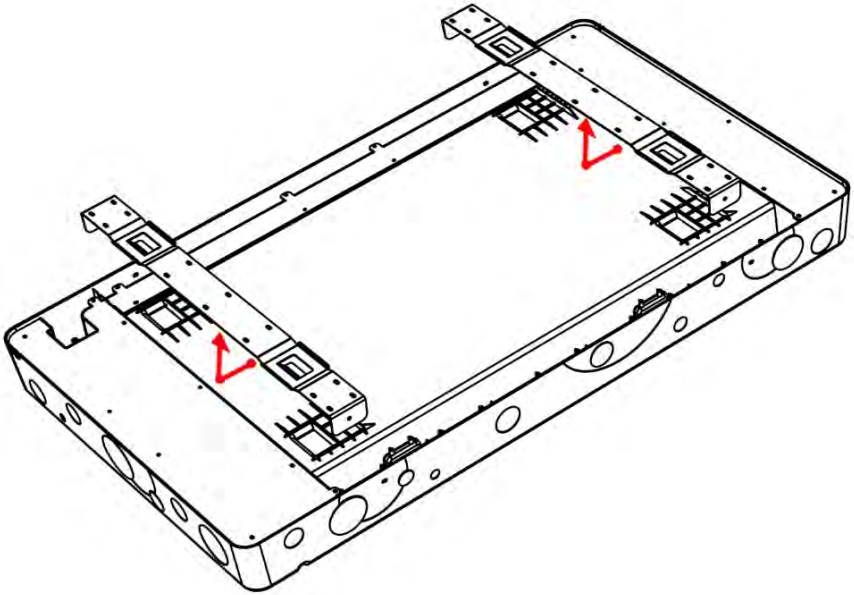

3. Hold the panel where you would like it to be mounted ensuring it is level. Whilst in position mark where the centre of the bracket mounting holes are on the wall. Do this for all 4x bracket mounting holes.

Place the panel safely to the side.

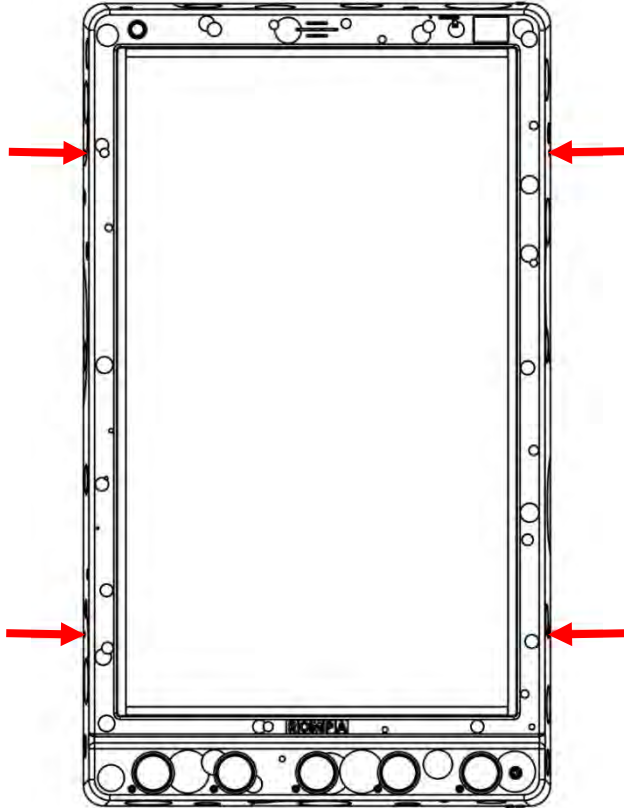

4. Secure both brackets to the wall* ensuring the centre of the bracket mounting holes line up with the marks just made to ensure the bracket is level when mounting it to the wall. The top bracket mounting holes should line up with the top 2x marks and the bottom bracket mounting holes should line up with the bottom 2x marks.

*Fasteners are not supplied and must be purchased separately. Please ensure the correct fasteners are used dependant on the construction of wall in question.

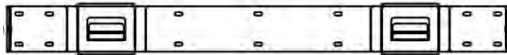
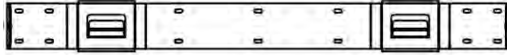

5. Clean the wall and brackets of any dust and debris which may have been created whilst mounting the brackets.

Insert one end of the floor pad cable into the floor pad and the other into the wall panel. Tighten the integrated screws.

Place the panel on brackets. To do this have the panel slightly higher than its final resting position. When you feel the panel has slotted into the bracket gradually lower the panel into position.

Reinstall the 4x M4 screws into the mounting bracket holes.

Safety

Installation

- Panel must be installed indoors in a dry environment. Do not install the panel where it may be subject to excessive heat or moisture as this may damage the product or reduce the product's lifespan.
- Ensure any packaging is disposed of correctly. Plastic bags can be a suffocation risk.
- Ensure the panel is mounted by suitably competent or qualified people. Improper mounting could result in injury. Care should be taken to the type of wall you are mounting the panel to and the appropriate fixings which should be used.
- Consider the height at which you are mounting the panel. The age of the primary user and whether they should be seated or standing should dictate the height at which the panel is mounted.

Operation

- **Panel must always be used under supervision.**
- Do not strike the panel. The panel is built robustly but intentional misuse will shorten the product's lifespan.
- Do not open or attempt to repair the panel yourself as this may cause injury and invalidate the warranty.
- Disconnect any cables when installing or moving the product. Pulling of the cables can cause premature wear or damage to the product and/ or accessories.
- If the product generates abnormal sounds, a burning smell or smoke disconnect immediately and contact Rompa® customer services.
- Do not press and hold the panel push buttons for durations of longer than a minute. Over time this may reduce the life expectancy of the product.

Care and Maintenance

To prolong its product life, please read the following instructions when installing and operating this panel:

- When installing please ensure to keep the layer of protective film on the screen on until the whole panel is fully mounted and is ready for use.
- Ensure no sharp tools or objects are near to the screen.
- Rompa® recommends to use a soft microfibre cloth for cleaning and dusting. It optimises the finish and will prevent scratches onto the screen.
- Slightly dampening the cloth or use of isopropyl alcohol is recommended for more stubborn stains. Ensure the panel does not become wet.
- Particular care should be taken around apertures in the chassis and any electronics (touch screen, power button, illuminated push buttons, external switch jacks and microphone input jack).
- Avoid food or drinks near this panel.
- Do not attempt to physically damage the product including the electronics, screen and buttons.
- Ensure loose wires are out of sight.

At the end of the product's life please dispose of the product ethically:

- Product can be taken to local recycling centre. Visit [RecycleNow.com](https://www.recycle-now.com) to find your local recycling centre.
- Some councils offer a household recycling collection service. Contact your local authority for more details.

Troubleshooting

No Sound	Ensure volume is on and turned up to a sufficient level via the touch screen.
	Turn the panel off and wait 10 seconds. Turn the panel back on. This will reset the panel settings and revert the sound to volume 2 and Sound Effects set to on.
	If troubleshooting does not solve the issue please contact Rompa® Customer Services +44 (0) 1246 211 777
Frozen or Unresponsive	Turn the panel off and wait 10 seconds. Turn the panel back on. This will reset the panel and revert the 1 st mode shown on Touch Screen.
	If troubleshooting does not solve the issue please contact Rompa® Customer Services +44 (0) 1246 211 777
Push Button(s) Unresponsive	Ensure panel buttons are not locked via the touch screen.
	Turn the panel off and wait 10 seconds. Turn the panel back on. This will reset the panel settings and revert the panel buttons to unlock.
	If troubleshooting does not solve the issue please contact Rompa® Customer Services +44 (0) 1246 211 777
External Switch Unresponsive	Ensure the switch inlet is clear of any dust or debris.
	Ensure the switch is fully inserted into the inlet.
	Ensure panel buttons are not locked via the touch screen.
	Turn the panel off and wait 10 seconds. Turn the panel back on. This will reset the panel settings and revert the panel buttons to unlock.
	If troubleshooting does not solve the issue please contact Rompa® Customer Services +44 (0) 1246 211 777
No Power	Ensure the mains is off before checking the power cable is fully inserted into the panel and then turn the mains back on.
	Check the power lead's fuse.
	If troubleshooting does not solve the issue please contact Rompa® Customer Services +44 (0) 1246 211 777

For further copies of this manual, please visit www.Rompa.com to access the instruction booklet.