

Double Bubble Bonanza™

Instruction Manual

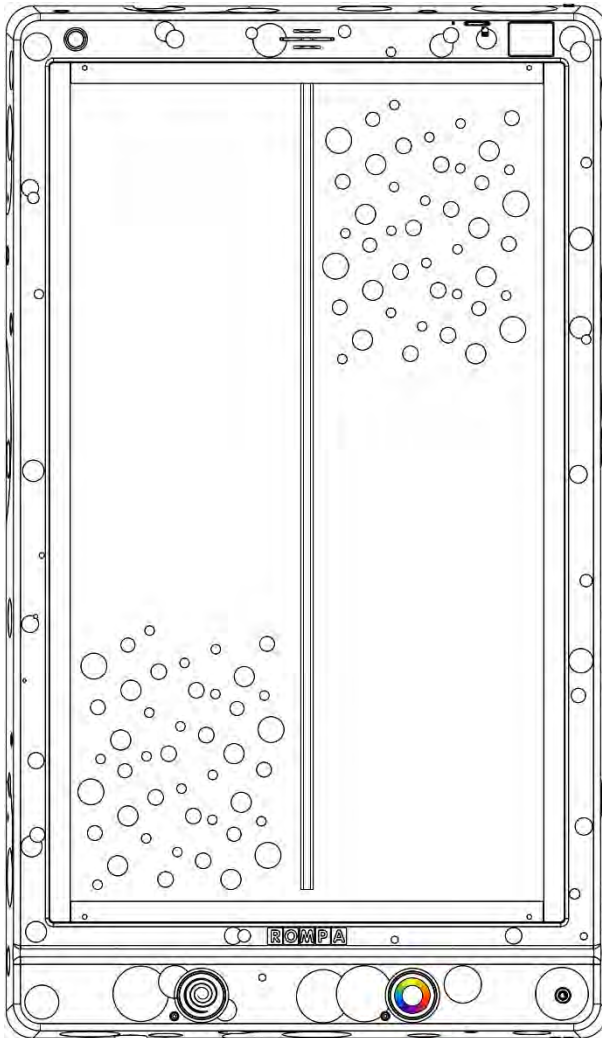

Contents

3	Panel Overview
4	Colour
4	Description
4	Technical Specification
5	Dimensions
6	Contents
6	Compatible Rompa® Products
7	Operation
7	Modes
8	Touch Screen
12	Illuminated Push Buttons
12	Patterns and Colours
15	External Switches
15	Microphone Input
16	Rompa® Wireless Operation
18	Installation
33	Safety
34	Care and Maintenance
36	Troubleshooting

Panel Overview

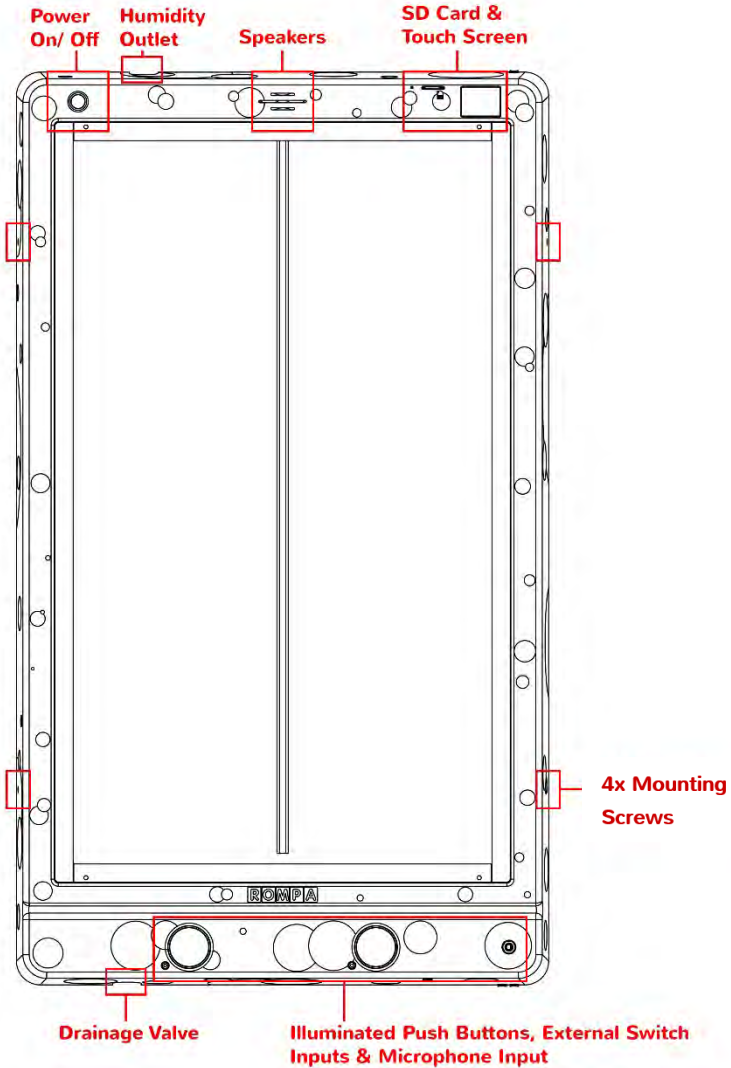

Colour

The Panel is available in 7 colours: Black, White, Blue, Red, Green, Lilac, & Ice Blue.

Description

Control the bubbles and colours in each of the Double Bubble Bonanza™ chambers. Be amazed as bubbles dissipate in one chamber only to burst into life in the other.

The panel is packed with sound effects and music which makes for a truly exciting multi-sensory experience. With a huge range of effects to choose from! The stunning effects stimulate, empower and engage. Perfect for co-operative play, turn taking and follow-my-lead activities.

Technical Specification

Weight:	23Kg
Weight tank when is full:	28-33Kg
Material:	ABS (Phthalate-Free)

UK and Europe	Input: 230-240V
	Output: 12V AC

US	Input: 110V
	Output: 12V AC

Dimensions

(All dimensions in mm)

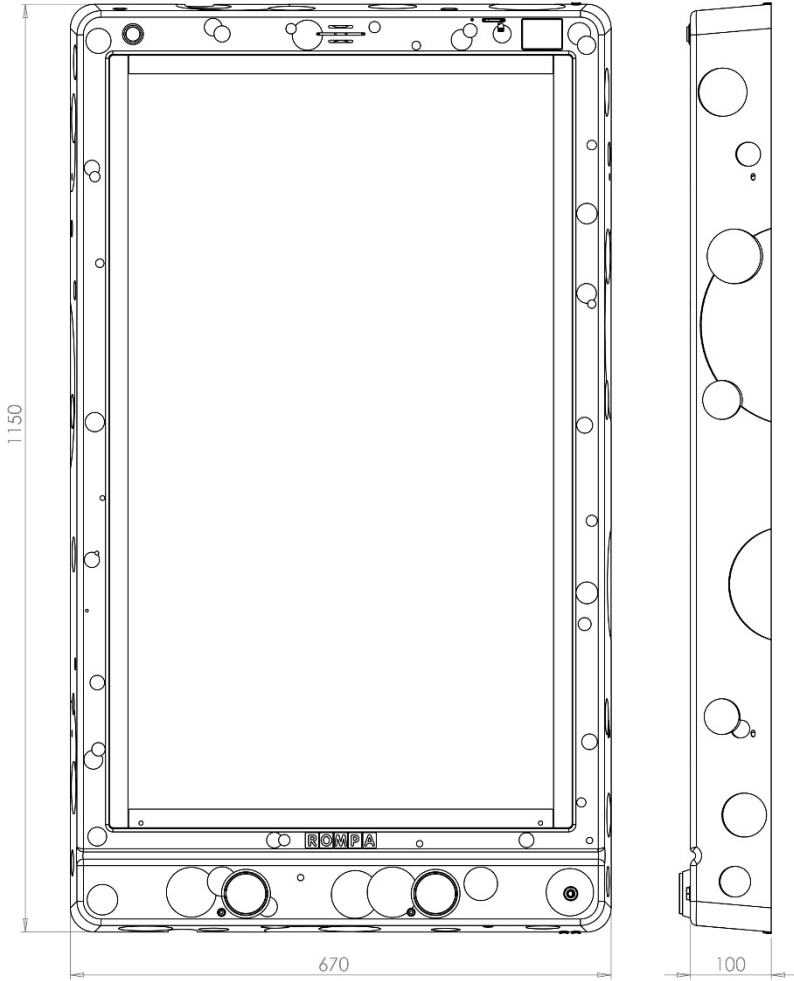

Contents

1 x Double Bubble Bonanza™

1 x UK/European Power Supply or US Power Supply

Recommended products

20908 Bubble Tube Filling Pump

Compatible Rompa® Products

20848 Sensory Magic®

21098 Sensory Magic Portable®

19847 Deluxe 8 Colour Wirefree Controller

21006 8 Colour Wirefree Switch

19939 WiFi Interactive Mat Switch Set

18870 Talking Cube

20402 Mini Talking Cube

21917 WiFi Microphone

24515 Colour Command Centre™

21918 WiFi Override Transmitter

21728 Rompa® WiFi App Control Box

22716 Rompa® WiFi Colour Control Bumpas – set of 8

22867 Wireless Colour Controller Cushioned Wall Mat

Operation

Modes

The mode dictates how the panel behaves. The Double Bubble Bonanza™ has 3 modes which can be selected via the touch and an additional mode when one or two microphones are plugged into the ¼"/6.35mm microphone input:

Mode 1: Interactive

The panel does not change current pattern or colour unless told to do so via the illuminated push buttons.

Mode 2: Creative

Control the bubbles in each chamber via the two push buttons. Pressing the button on the left (Pattern) activates bubbles in the left chamber of the panel. Pressing the button on the right (Colour) activates bubbles in the right chamber of the panel. Bubbles are triggered when the button is pressed so a short burst of bubbles can be created by tapping the button(s) or a longer stream can be created by holding the button(s).

Mode 3: Music and Sound Effects

Music and sound effects are paired with each pattern for a more stimulating multisensory experience. The panel works as Mode 1: Interactive.

Microphone Mode

This mode cannot be accessed via the touch screen. To access this mode plug a microphone into the ¼"/6.35mm microphone input. The panel will automatically change to microphone mode once a microphone has been detected. The mode and brightness of the panel cannot be adjusted via the touchscreen whilst a microphone is plugged in.

When the microphone detects a sound a burst of bubbles is produced.

Touch Screen

The touch screen is intended for the supervisor of the session, not the primary user of the panel. The touch screen allows you to control in detail how the panel behaves as well as view statistics of panel usage.

Upon booting the panel up it will revert to its default settings:

Mode 1: Interactive

Volume: 2

Touch Screen Brightness: 100%

Panel Brightness: 100%

Sound Effects: On

WiFi: On

Lock: Off

**Mode**

Press the light blue mode button to cycle through the modes of the panel.

Press the Red forward or back buttons to cycle through the other menu options.

**Media***

Press the 'play/ pause' button to play or pause music. Press the 'skip forward' to play the next track or 'skip back' to play the previous.

Press the red forward or back buttons to cycle through the other menu options.

*This functionality may only be available when an SD card has been inserted.

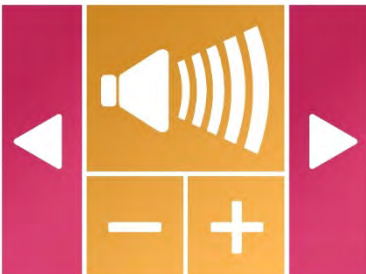
**Volume**

Pressing the '+' will increase the volume and pressing '-' will reduce the volume.

Press the red forward or back buttons to cycle through the other menu options.

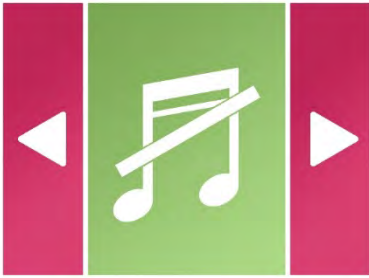

Sound Effects

Pressing the light green sound effect button will cycle the sound effects on or off. Sound effect refers to the sounds made when the user activates the illuminated push buttons.

Press the red forward or back buttons to cycle through the other menu options.

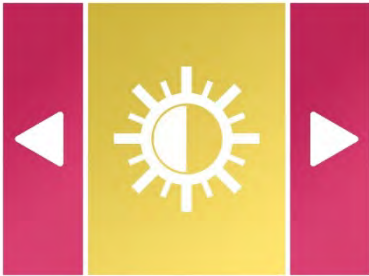

Touch Screen Brightness

Pressing the yellow screen brightness button will cycle the panel through 6 levels of brightness to 100%.

Press the red forward or back buttons to cycle through the other menu options.

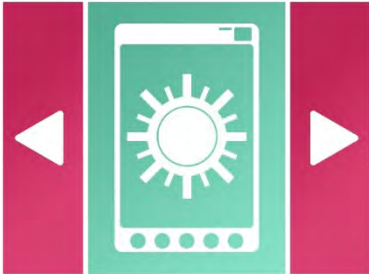

Panel Brightness

Pressing the turquoise screen brightness button will cycle the touch screen through 3 levels of brightness to 100%.

Press the red forward or back buttons to cycle through the other menu options.



Lock

Pressing the red lock button will lock and unlock the illuminated push buttons. When locked the push buttons will dim and be unresponsive.

Press the red forward or back buttons to cycle through the other menu options.

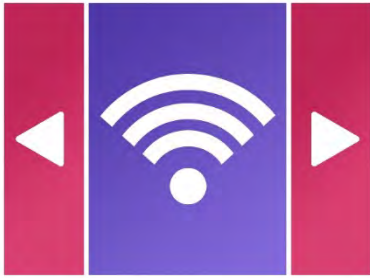

Wireless

Pressing the purple wireless button will cycle the panel wireless on or off. With wireless turned on the panel will respond to other Rompa® compatible wireless products. With wireless turned off it will ignore Rompa® compatible wireless products (Page 6).

Press the red forward or back buttons to cycle through the other menu options.



Stats

Pressing the blue stats button will open the stats screen.

From the stats screen you can see in real time the amount of button presses that have been made on the panel and the duration the panel has been used for.

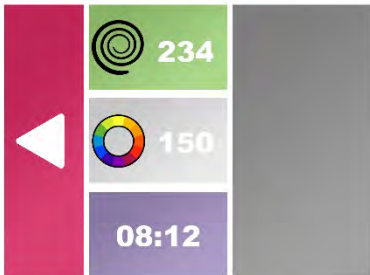

To return to the main menu, press the red back button.

Press the red forward or back buttons to cycle through the other menu options.

Illuminated Push Buttons

The Double Bubble Bonanza™ has 2 illuminated push buttons so the user can control the visual and audio effects the panel produces. When pressed, each button will flash and a unique sound effect will be triggered. Sound effects can be turned off via the touch screen (Page 9). Illuminated buttons can also be locked via the touch screen if required. The brightness of the illuminated buttons is reduced and the buttons are unresponsive when locked (Page 10, Lock setting). When using the Wireless setting (Page 10) it would benefit in keeping the same illuminating setting on while using other Rompa® products.



Pattern

The panel has 3 patterns which can be selected via the 'Pattern' illuminated push button or an external switch plugged into the 'Pattern' ¼"/6.35mm input jack.

Colour

The panel has 14 colours which can be selected via the 'Colour' illuminated push button or an external switch plugged into the 'Colour' ¼"/6.35mm input jack.

Patterns and Colours

Patterns

- 1 No Pattern
All LEDs are illuminated with no change.
- 2 Bubble Burst
A burst of bubbles will flow up both channels followed by a break. The pattern then repeats.
- 3 Alternate Bubble Burst
A burst of bubbles with the 1st chamber on, the other chamber turns bubbles off simultaneously. Then it turns opposite with 1st chamber turn off and a burst of bubbles on the other chamber. This cycle is then repeats.

Colour

- 1 Multi-Coloured (LEDs are multi-coloured)
- 2 All Colours Soft Fade (LEDs transition through colours)
- 3 All Colours Hard Fade (LEDs hard transition through colours)
- 4 Red

- 5 Green
- 6 Blue
- 7 Yellow
- 8 Orange
- 9 Pink
- 10 Purple
- 11 White
- 12 Individual Chambers Soft Fade (LEDs transition through colours – each chamber is a different colour)
- 13 Individual Chambers Hard Fade (LEDs hard transition through colours – each chamber is a different colour)
- 14 Colour Chase (LEDs change colour in time with the rising bubbles – Bubble Burst and Alternating patterns only)

External Switches

The panel has 2 external switch inputs each located next to their associated illuminated push button. To connect the external switch simply plug into the ¼"/6.35mm jack and remove when finished (external switches without a ¼"/6.35mm may need an adapter fitting).

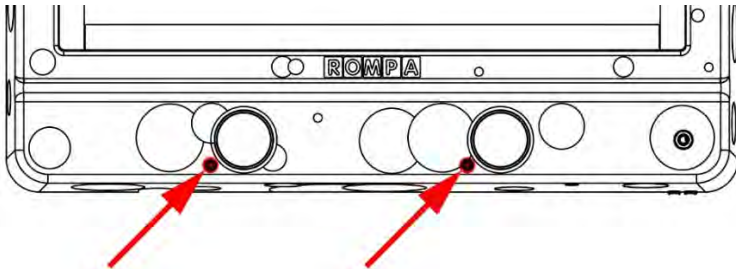

Microphone Input

The panel has 1 microphone input. To use a microphone with the panel simply plug a microphone into the ¼"/6.35mm jack located in the bottom right of the panel. When the microphone is inserted the panel will automatically detect its presence and turn to 'Microphone Mode'. The panel also acts as a karaoke and sounds spoken through the microphone can be heard through the integrated speaker. When the microphone is removed from the panel, the panel will automatically revert back to its previous mode.

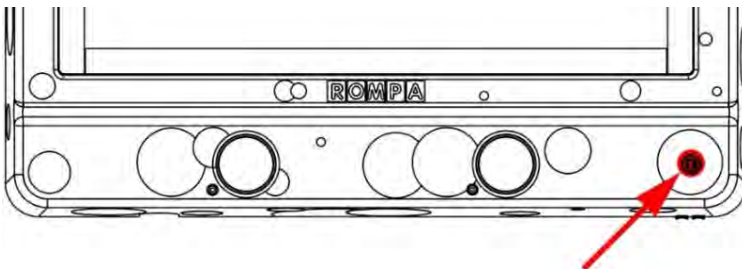

Rompa® Wireless Operation

The Double Bubble Bonanza™ is compatible with a range of Rompa® wireless products (see page 6):

8 Colour Wirefree Controller: Simple and Deluxe

Pressing the colour buttons turns both chambers to the corresponding colour selected. The panel will remain this colour unless a new colour is selected via the panel, a Rompa® wireless controller or the panel is in a passive mode where it continues cycling through colours and patterns after 60 seconds.

The Function Button acts differently in each of the panel's 3 modes.

Mode 1:

During Mode 1 the function button acts as a Play/Pause button enabling the user to freeze the pattern in its current state.

Mode 2:

During Mode 2 pressing the function button triggers the panel to release a short burst of bubbles in each chamber.

Mode 3:

This is an automated musical function where the bubbles are automatically pumped by sequence of musical themes. The user can pause the pump and lighting while still playing the music tunes.

Other Wireless Products

Selecting a colour changes all the LEDs in array to the corresponding colour selected. The panel will remain this colour unless a new colour is selected via the panel, a Rompa® wireless controller or the panel is in a passive mode where it continue cycling through colours and patterns after 60 seconds.

Installation

Installing Wall Bracket, Tank & Panel

Due to the size and weight of the product it is highly recommended that it is installed by two people.

Ensure that, after installation, the mains plug and/or power switch for the Panel is easily accessible to facilitate removal of power.

Ensure that at least one of the two people mounting the panel is deemed competent as. Improper mounting could result in injury and any damage caused would invalidate the warranty.

Due to the weight of the product it must only be installed onto walls of appropriate construction and with the appropriate fixings. This product is not suitable for fitting onto the Rompa® Panel Porter (22879).

Recommended Tools

- Drill
- Spirit Level
- Pencil
- Tape Measure
- Appropriate Fixings (e.g. Wall plugs, etc.)

(All dimensions in mm)

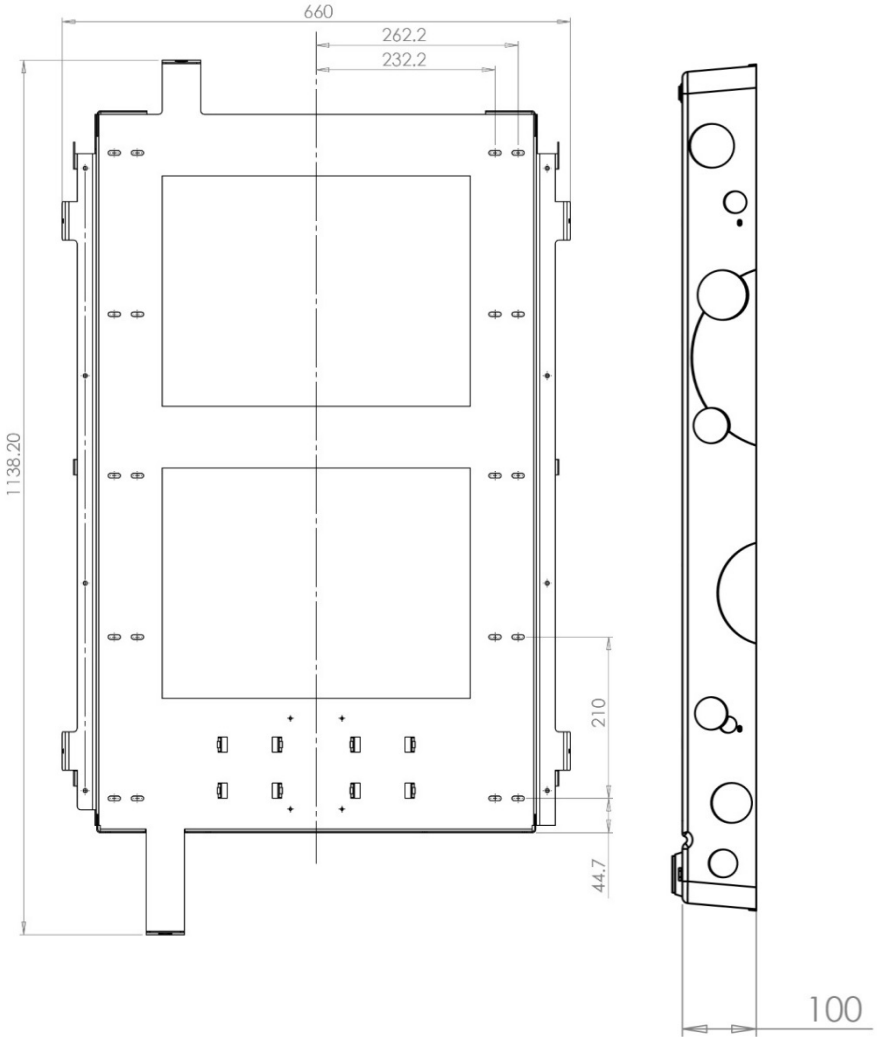

1. Lay the panel on its back ensuring the screen is facing upwards. Unscrew the 4 x M4 screws which secure the panel cover to the wall bracket. Please keep these in a safe place until required later.

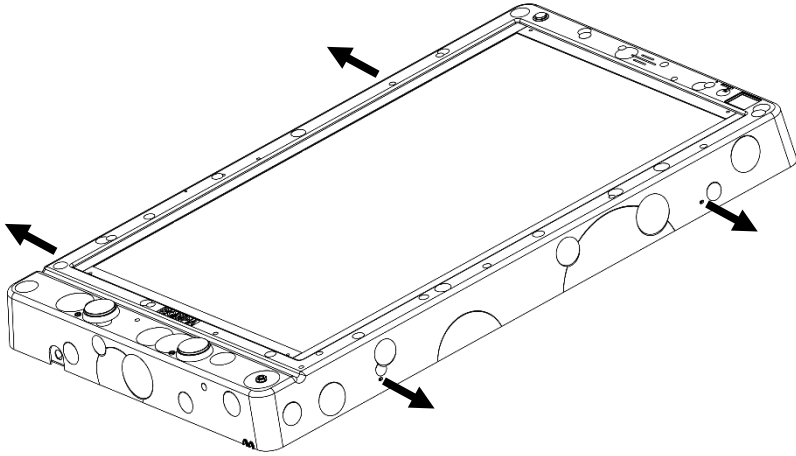

Next remove the framework from the TOP of the panel where the touchscreen locates, as shown the illustration below.

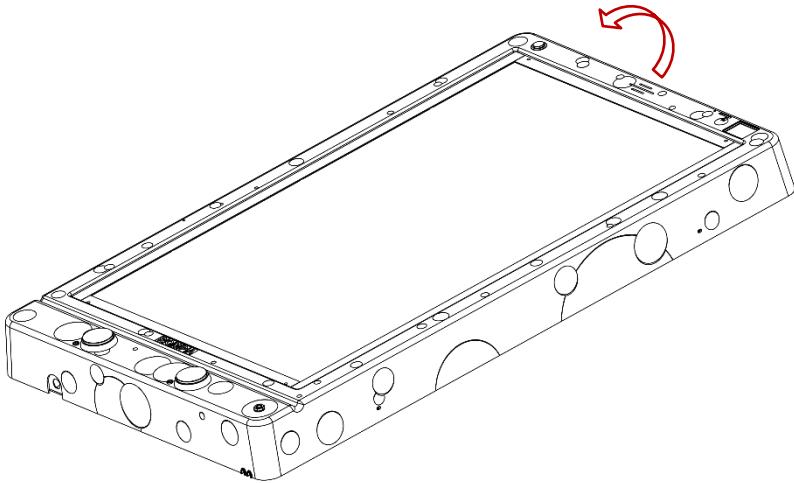

2. Remove the screws from the tank and then carefully remove the tank from the bracket. Place both the screws and the tank safely to one side as it will be required in step 5.

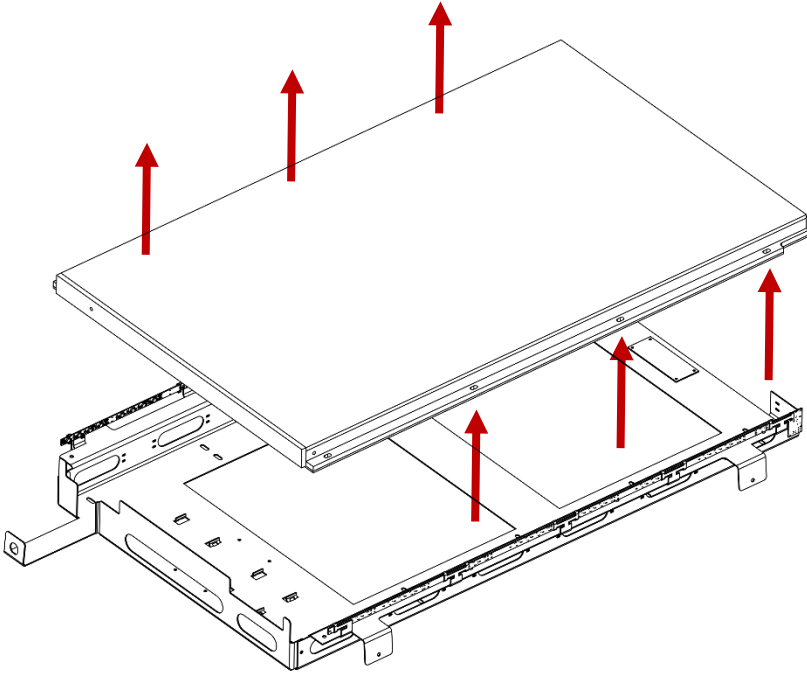

3. Person 1 will hold the bracket against the wall in place ensuring it is level, while the person 2 will need to mark the bracket position and screw positions as highlighted below.

It is highly recommended that you use a minimum of 6 screws for mounting. The bracket and fixings on the wall must be able to hold the weight of the panel when filled with water.

Place the bracket in a safe place before drilling.

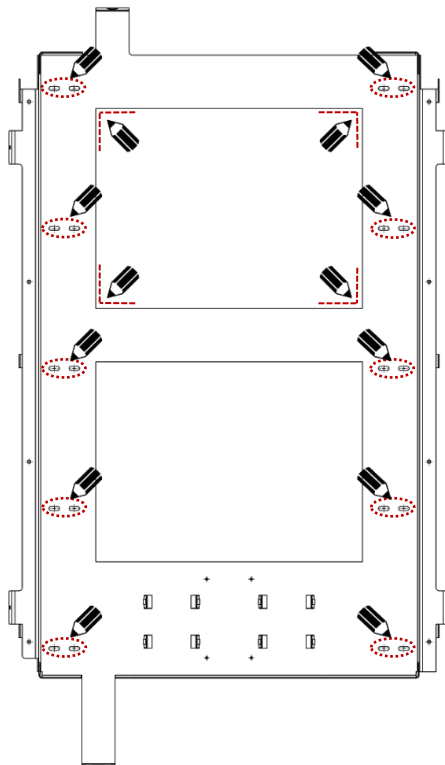

4. Drill a minimum of 6 x M6 holes in your marked screw positions

Secure the bracket to the wall using wall plugs and M6 screws.

Please note: fasteners are not supplied and must be purchased separately.

Please ensure the correct fasteners are used dependant on the construction of the wall in question.

- Align the tank and the bracket carefully, using the screws (already provided) to mount in place.

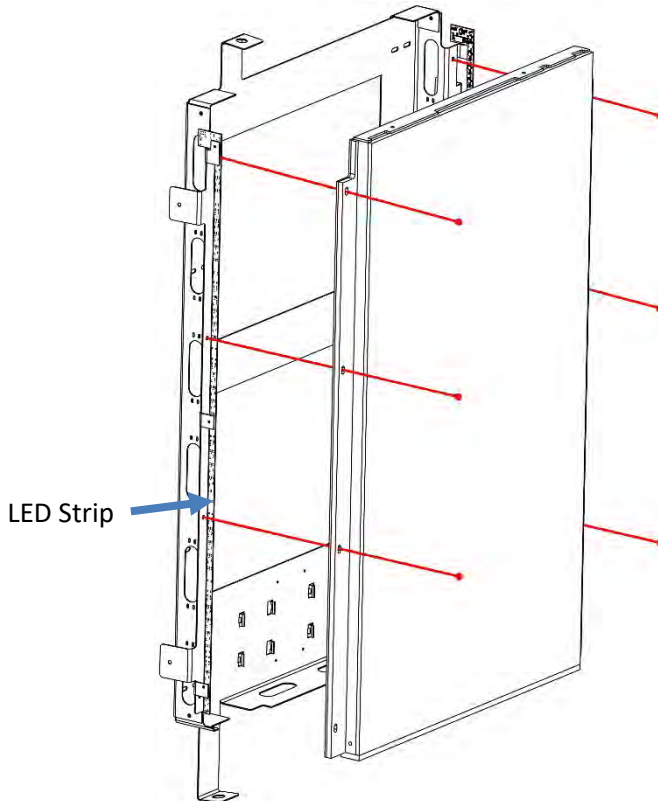

Please ensure all tubes, wires and LED strip (position from its sides) do not get trapped or damaged.

- Connect the Thick Clear Drainage Tube to the outlet valve on the bottom of the tank.

Connect the 2 x Thin Orange Air Inlet Tubes to the air inlets on either side of the tank.

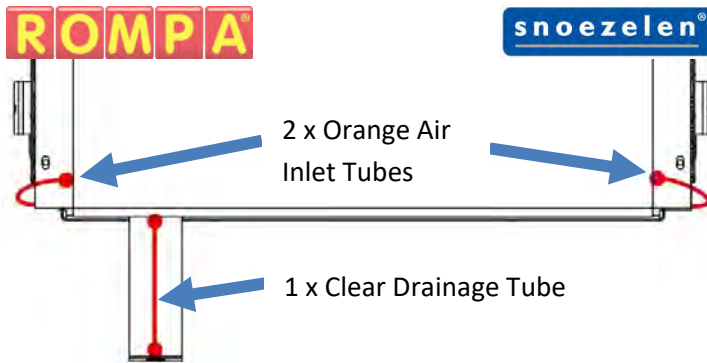

7. Ensure that the product is **NOT** plugged into the mains and your work area is clear from any potential hazards.

Remove the tank lid and fill the tank with water. Ensure the water level leaves a 50mm/2 inch gap from the top of the tank. **DO NOT OVERFILL**, as this will cause water to overflow and potentially cause water damage. The water level will fluctuate as the pump operates pumping the bubbles.

Recommend: Use Distilled water for long lasting performance.

Pump Filling

Rompa® strongly recommends the 20908 Bubble Tube Filling Pump as the quickest and safest way to fill and drain the tank. Refer to 20908 Bubble Tube Filling Pump instructions for a more comprehensive guide on using this product.

Plug the pump output into the tank drainage valve. Place the pump inlet into a water source and turn the pump on. Turn the pump off when the tank is filled.

Manual Filling

If you are filling the tank manually however use a funnel or similar to avoid any spillage of water and fill the tank from the top. Replace the tank lid.

- At the top of the bracket connect the Orange Thin Humidity Outlet Pipe to the outlet valve at the top of the tank.

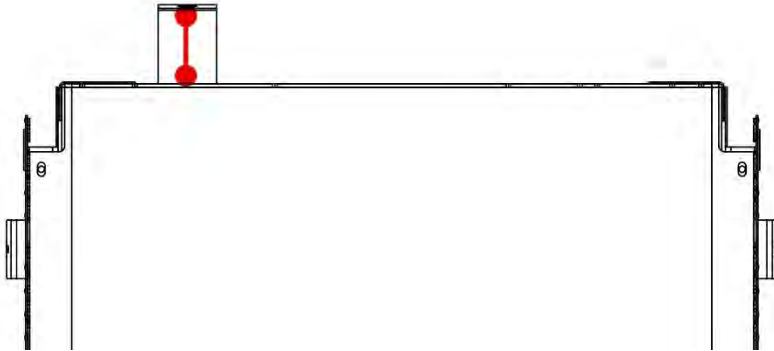

- Plug the External Power Supply to the cable located at the bottom of the bracket.

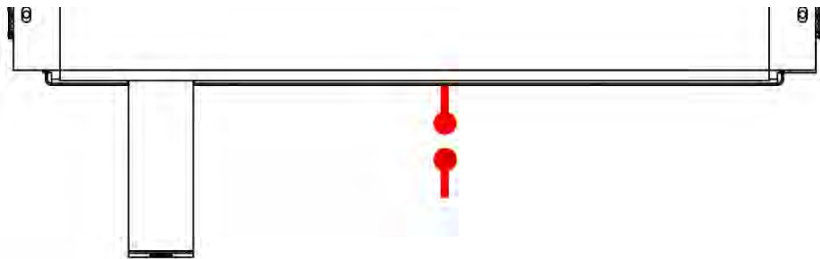

DO NOT plug the External Power Supply into the mains or attempt to turn the product on at this stage.

10. Position the bottom of the framework against the bottom of the bracket as shown below. Connect all 3 cables from the bracket to the electronic board inside the framework. The electronic board is behind the touchscreen display.

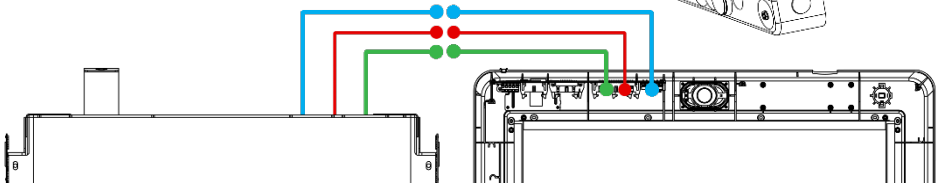
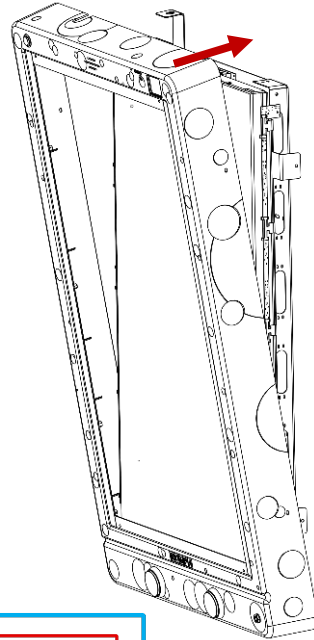

Connect the 3 different sized cables in the order shown below. As they are different sizes, they will only connect to each other in one way.

1. The thinnest connector should be fitted at the centre back of the electronic board.
 2. The widest connector fits in front of the thinnest connector.
 3. The medium sized connector fits next to the widest connector on the left.
11. Before you plug into the mains, test the panel's set up:
- a. Water level – is there a gap of 50mm/2 inch at the top of the tank? If not, adjust the water level allowing a 50mm/2 inch gap.

- b. Are there any water leaks at the bottom of the tank?
 - If the leak is coming from the orange tube connectors, drain first and make sure that the tube is fully sealed and connected.
 - If the leak is coming from the drain valve (bottom of the tank), make sure that it is fully attached and closed properly.

If set up correctly without any leaks, plug the product into the mains and check the following:

- c. Are both LED Strips working as expected?
- d. Are both Pumps working and are bubbles being produced in both chambers of the tank?

If so, fit the framework onto the bracket and secure.

- 12. Carefully place the framework over the bracket ensuring that all the metal tabs of the bracket sit within the framework.

Ensure wires and tubing are not pinched and are out of sight within the cover.

13. Secure the cover with the 4 x M4 bolts saved from earlier.

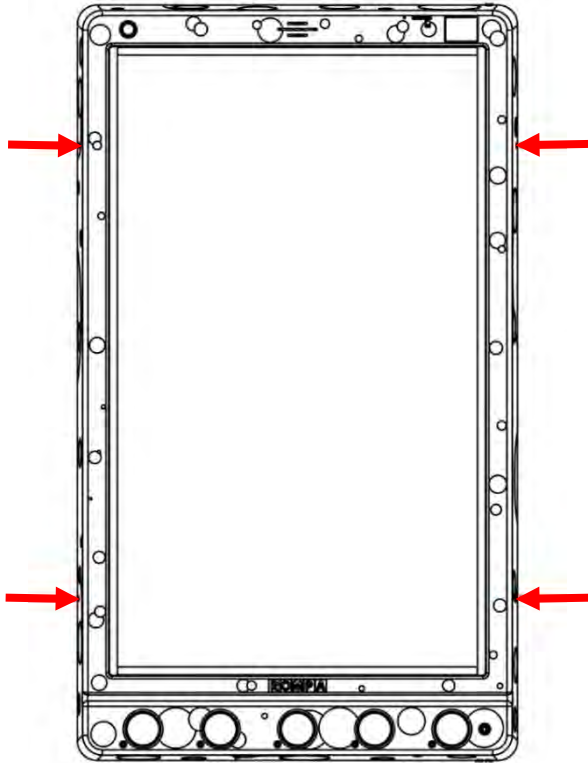

Safety

Installation

- Panel must be installed indoors. Do not install the panel where it may be subject to excessive heat or moisture as this may damage the product or reduce the product's lifespan.
- Do not place this with direct sunlight, this will promote algae growth.
- Ensure any packaging is disposed of correctly. Plastic bags can be a suffocation risk.
- Ensure the panel is mounted by suitably competent or qualified people. Improper mounting could result in injury. Care should be taken to the type of wall you are mounting the panel to and the appropriate fixings which should be used.
- Consider the height at which you are mounting the panel. The age of the primary user and whether they should be seated or standing should dictate the height the panel is mounted.

Operation

- **Panel must always be used under supervision.**
- Do not strike the panel. The panel is built robustly but intentional misuse will shorten the product's lifespan.
- Do not open or attempt to repair the panel yourself as this may cause injury and invalidate the warranty.
- Disconnect any cables when installing or moving the product. Pulling of the cables can cause premature wear or damage to the product and/ or accessories.
- If the product generates abnormal sounds, burning smell or smoke disconnect immediately and contact Rompa® customer services.
- Do not press and hold the panel push buttons for durations of longer than a minute. Over time this may reduce the life expectancy of the product.

Care and Maintenance

To prolong its product life, please read the following instructions when installing and operating this panel:

- When installing please ensure to keep the layer of protective film on the screen until the whole panel is fully mounted and is ready for use.
- Ensure no sharp tools or objects are near to the screen.
- Rompa® recommends to use a soft microfibre cloth for cleaning and dusting. It optimises the finish and will prevent scratches onto the screen.
- Slightly dampening the cloth is recommended for more stubborn stains. Ensure the panel does not become wet. Wipe the exterior of the panel with a slightly damp cloth. Never use solvent-based cleaning products, methylated spirits, alcohol wipes or liquid detergents to clean this product.
- Particular care should be taken around apertures in the chassis and any electronics (touch screen, power button, illuminated push buttons, external switch jacks and microphone input jack).
- Avoid food or drinks near this panel.
- Do not attempt to physically damage the product including the electronics, screen and buttons.
- Ensure loose wires are out of sight.

At the end of the product's life please dispose of the product ethically:

- Product can be taken to local recycling centre. Visit [RecycleNow.com](https://www.recycle-now.com) to find your local recycling centre.
- Some councils offer a household recycling collection service. Contact your local authority for more details.

Troubleshooting

No Sound	Ensure volume is on and turned up to a sufficient level via the touch screen.
	Turn the panel off and wait 10 seconds. Turn the panel back on. This will reset the panel settings and revert the sound to volume 2 and Sound Effects set to on.
	If troubleshooting does not solve the issue please contact Rompa® Customer Services +44 (0) 1246 211 777
Frozen or Unresponsive	Turn the panel off and wait 10 seconds. Turn the panel back on. This will reset the panel and revert the 1 st mode shown on Touch Screen.
	If troubleshooting does not solve the issue please contact Rompa® Customer Services +44 (0) 1246 211 777
Push Button(s) Unresponsive	Ensure panel buttons are not locked via the touch screen.
	Turn the panel off and wait 10 seconds. Turn the panel back on. This will reset the panel settings and revert the panel buttons to unlock.
	If troubleshooting does not solve the issue please contact Rompa® Customer Services +44 (0) 1246 211 777
External Switch Unresponsive	Ensure the switch inlet is clear of any dust or debris.
	Ensure the switch is fully inserted into the inlet.
	Ensure panel buttons are not locked via the touch screen.
	Turn the panel off and wait 10 seconds. Turn the panel back on. This will reset the panel settings and revert the panel buttons to unlock.
	If troubleshooting does not solve the issue please contact Rompa® Customer Services +44 (0) 1246 211 777
No Power	Ensure the mains is off before checking the power cable is fully inserted into the panel and then turn the mains back on.
	Check the power lead's fuse.
	If troubleshooting does not solve the issue please contact Rompa® Customer Services +44 (0) 1246 211 777

For further copies of this manual, please visit www.Rompa.com to access the instruction booklet.